

AUDITORIUMS

inno^{fi}

inno^{fi}

Inno started manufacturing personal looking and timeless products that stand out of the mass in 1975. Today Inno is known of it's internationally awarded collection. Inno develops innovative products of high quality to meet the most demanding requirements of public interiors.

"We strongly believe that a good product has to give more than a look and a function, it has to feel right".

www.inno.fi

TOOLS FOR ARCHITECTS



SELECTUM

SESSIO

SIMO

MIO

Inno has a wide range of auditorium chairs offering solutions for different needs. The main features of the chairs Selectum and Sessio (design Harri Korhonen), Simo (design Simo Heikkilä) and Mio (design Jouko Järvisalo) include applicability for most common depths and heights of steps, straight or curved rows, customizable dimensions in width and height, intermediate legs or a beam solution, one center leg, different materials and finishings. All models are available with or without armrests and optional folding, fixed or free standing writing tablets.

Ask for a best custom solution for your project after particular specifications.

2d & 3d cad files available for planning purposes on our web www.inno.fi

SELECTUM

Selectum is a highly versatile auditorium chair with many upholstery and finishing options. Its slightly curved shell gives perfect comfort even for longer sitting. The basic form is practical - the generous Selectum looks natural and aesthetic in rows. A single fixed chair can easily be grouped to curved or straight rows to form different set-ups with variable distance between chairs etc. Optional armrests and a folding writing tablet. Designed as part of Select chair series with many different models in same style.

Design: Harri Korhonen





Project model with a veneered seat and back panel.

SESSIO

Sessio is an auditorium or beam seat solution with optional arms. Sessio has an upholstered veneer seat and a mesh backrest. The frame is epoxy coated.

Design: Harri Korhonen





Optional folding writing tablet



Optional armrest



The Simo auditorium chair gives a pleasant feeling to any interior with its elegant plastic forms and ergonomic seating comfort. There are several possibilities for writing tablets: fixed, or foldable either from the backrest or armrest.

Design: Simo Heikkilä







The Mio auditorium chair with wooden backrest and seat creates a continuous wave, giving a special character to interiors. The frame can be fixed to declining floors in different ways and offers several solutions for fixing writing tablets to the leg structure, backrest or armrest. Its rich details make Mio an outstanding choice.

Design: Jouko Järvisalo





SPECIFICATIONS

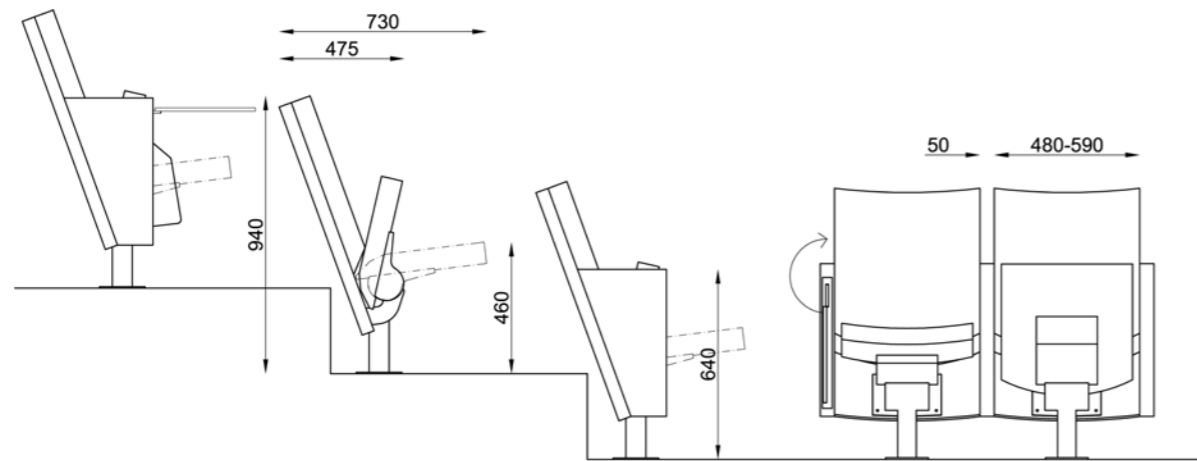

- SELECTUM design Harri Korhonen
- Totally upholstered
 - Free standing on one D60mm center leg
 - For straight or curved rows
 - Spring tip-up mechanism
 - Options: upholstered armrest, folding writing tablet

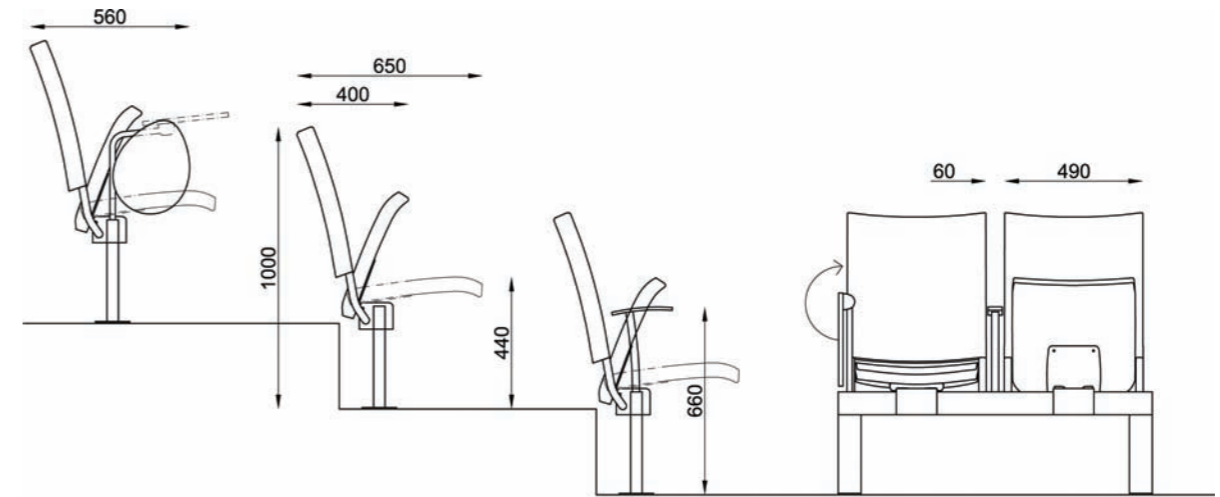
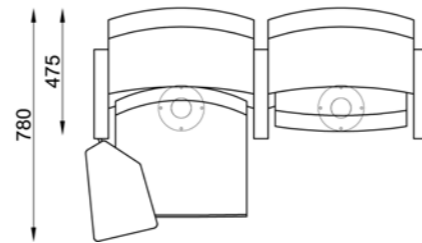

- SESSIO design Harri Korhonen
- Seat upholstered
 - Back mesh fabric
 - Beam (80x40mm) solution with legs every 3 or 4 seat
 - For straight or curved rows
 - Spring tip-up mechanism
 - Options: upholstered armrest, folding writing tablet

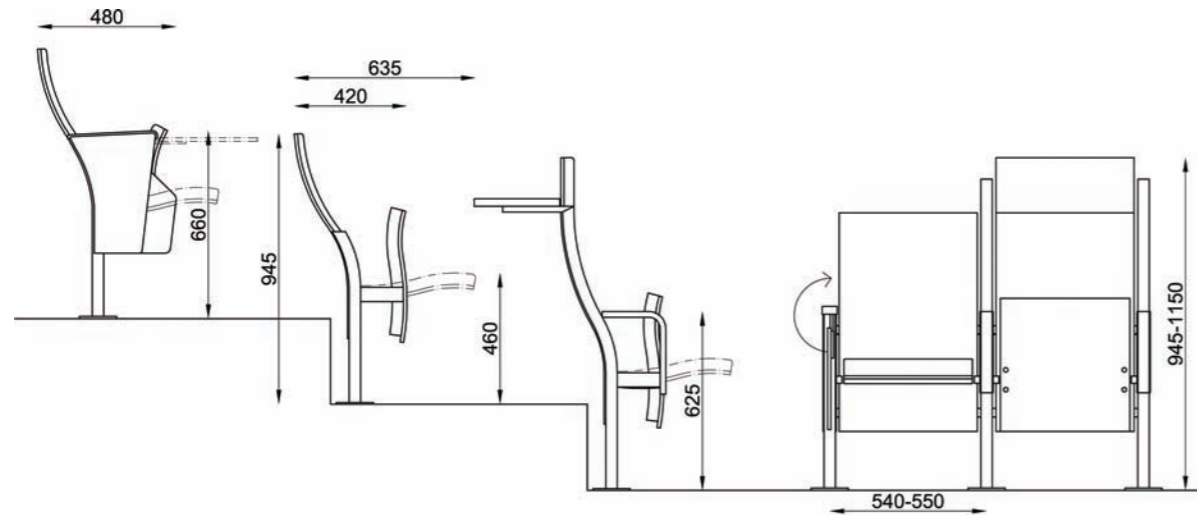
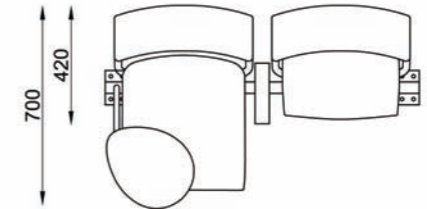

- SIMO design Simo Heikkilä
- Seat and back formpressed plywood
 - Upholstered seat and back
 - Intermediate legs 40x40mm tubular steel
 - For straight or curved rows
 - Counterweight tip-up mechanism
 - Options: wooden armrest (formpressed plywood), fixed or folding writing tablet, perforated seat

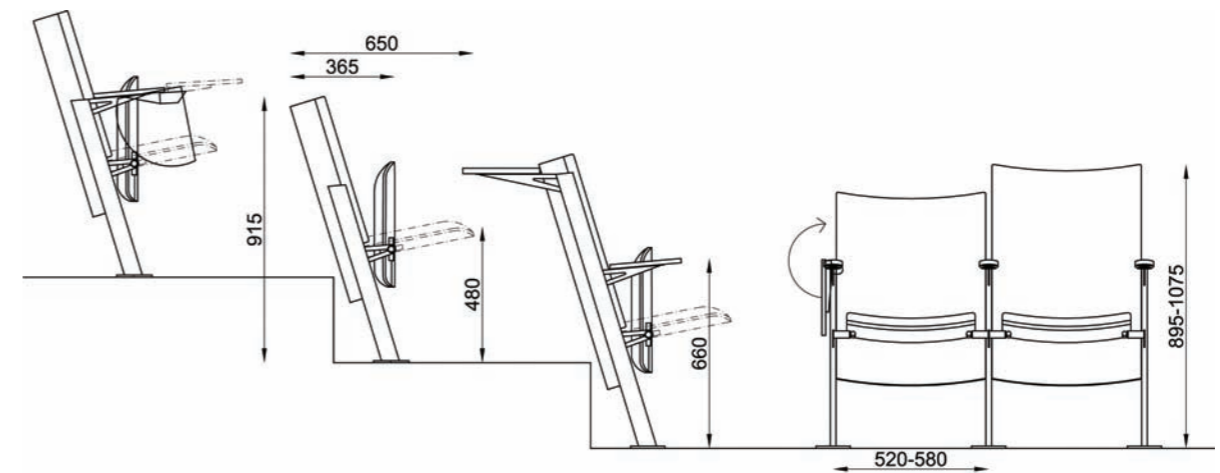
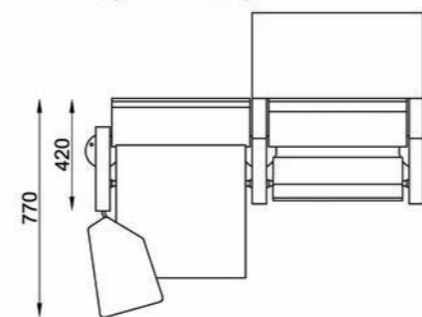

- MIO design Jouko Järvisalo
- Seat and back formpressed plywood
 - Upholstered seat and back
 - Intermediate legs 50x20mm oval tubular steel
 - For straight or curved rows
 - Counterweight tip-up mechanism
 - Options: upholstered armrest, fixed or folding writing tablet

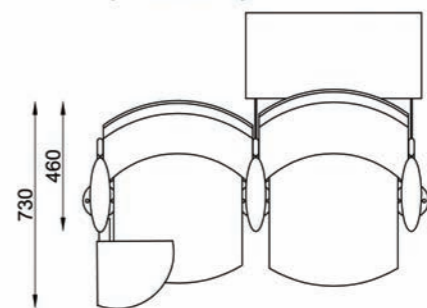

PROJECT MODELS



In addition to standard models we are specialized in custom made auditoriums by modifying an existing model or creating a totally new product for a specific project in cooperation with the architect and customer.



Kola, design Mikko Laakkonen



Select, design Harri Korhonen



Kuopio theatre, design ALA Architects



Opinmäki, design ERA Esa Ruskeepää Architects

SELECTED REFERENCES

Karolinska Institutet, Sweden 157 pcs Kola, year 2017

SANMF, Australia 215 pcs Selectum, year 2016

Medibothnia, Vaasa, Finland 40 pcs Selectum, year 2016

North Karelia Central Hospital, Joensuu, Finland 40 pcs Selectum, year 2016

L'oreal, Paris, France 14 pcs Selectum, year 2015

Gongress Universitetgaten, Sweden 30 pcs Selectum, year 2015

Kuopio Theatre, Finland 466 pcs Project model, year 2014

Innventia, Stockholm, Sweden 85 pcs Selectum, year 2013

Grossrat, Switzerland 64 pcs Sessio, year 2012

Central Bank, Norway 60 pcs Mio, year 2008

Prague, Czech Republic 75 pcs Simo, year 2007

Brooklyn Central Library, USA 200 pcs Mio, year 2006

Ruthers, USA 53 pcs Mio, year 2005

Uppgårdsskolan, Stockholm, Sweden 13 pcs Simo, year 2004

Clinton Presidential Center, Arkansas, USA 84 pcs Mio, year 2004

NE Biolabs, USA 191 pcs Mio, year 2004

Wärtsilä, Joensuu, Finland 160 pcs Simo, year 2004

Trinity University, New Northrup hall, USA 99 pcs Mio, year 2003

New York Public Library, USA 168 pcs Mio, year 2002

Eurac (Accademia Europea di Bolzano), Italy 326 pcs Mio, year 2002

Concert hall, Savonlinna, Finland 803 pcs Simo, year 2002

Tampere University of Technology, Finland 903 pcs Mio, year 2001

Helsinki University, Finland 280 pcs Project model, year 2001

Nokia Networks, Helsinki, Finland Mio 58 pcs, year 2000

Scandinavian house, New York, USA 174 pcs Mio, year 2000

Theatre Academy, Helsinki, Finland Mio 107 pcs, year 2000

Lynghesenteret, Bergen, Norway 48 pcs Mio, year 1999

Nizza, France 68 pcs Mio, year 1998

Fair Centre, Turku, Finland 700 pcs Mio, year 1995